

KT307

Telehandlers < 3.5t



KRAMER
on the safe side



The Kramer telehandler KT307 is a manoeuvrable all-round talent - compact dimensions combined with a stacking height of 7 metres and 3 tonnes of payload provide versatile operation in all agriculture applications. The powerful work hydraulics allow precise and overlapping movements with load-sensing characteristics, thus ensuring a high level of productivity on the farm. A variable, hydrostatic drive system and cleverly designed maintenance access make daily application and maintenance a breeze. The ergonomic and functional cab ensures stress-free working.

- Lift capacity: 3 tonnes of payload and a stacking height of 7 metres
- Economical consumption: Low fuel consumption and high torque (136 hp, emissions level V)
- Loader unit: The overall pivot angle of over 150° ensures complete bucket emptying, even when handling sticky materials
- Compactness: Compact dimensions allow easy operation, even in tight spaces
- Safety: The final position dampening provides gentle retraction and extension of the boom and prevents unwanted material loss

KT307 Technical specifications

Operating data

Max. payload (LSP 500 mm)	3,000 kg
Max. stack height	7,000 mm
Payload at max. stack height	2,000 kg
Payload bei max. Reichweite	1,000 kg
Stack height at max. payload	5,500 mm
Reach at max. payload	1,780 mm
Max. reach	3,760 mm
Operating weight (max.)	7,370 kg
Total swing angle of tool carrier	155 °
Bucket capacity	1 m ³

Engine / Motor

Engine / Motor manufacturer	Deutz
Type / Model	TCD 3.6 / L4
Engine performance	100 kW
Emission standards stage	V
Exhaust aftertreatment system	DOC + DPF + SCR

Power transmission

Traction drive	Hydrostat
Driving speed (standard)	30 km/h
Driving speed (option)	20 km/h
Differential lock	Self-locking differential 45% in the front axle
Standard tires	405/70-24

Operating hydraulics

Duty pump	Gear pump with LUVD
Max. pump discharge capacity	100 l/min
Max. pump pressure	260 bar

Filling capacities

Fuel tank	100 l
Hydraulic oil tank	100 l
DEF tank	9.5 l

Sound emission

Measured value	105 dB(A)
Guaranteed value	106 dB(A)
Noise level at the driver's ear	78 dB(A)

Vibrations

Total vibrations value of the upper body extremities	< 2,5 m/s ²
Highest effective value of weighted acceleration for the body	< 0,5 m/s ²

All statements without guarantee.

Payload at max. lift height: with hydraulic leveling

Stacking height at max. payload: with hydraulic leveling

Sound emission: The measurement occurs according to the requirements of the EN 1459 standard and the 2000/14/EC directive. Measuring area: asphalted surface

Vibrations: Uncertainty of measurement as specified in ISO/TR 25398:2006. Please instruct or inform the operator of possible hazards from vibrations.

Vibrations: Total vibrations value of the upper body extremities: on level and secure ground driving appropriately

Vibrations: Highest effective value of weighted acceleration for the body: use in extraction under harsh environmental conditions

KT307 Dimensions

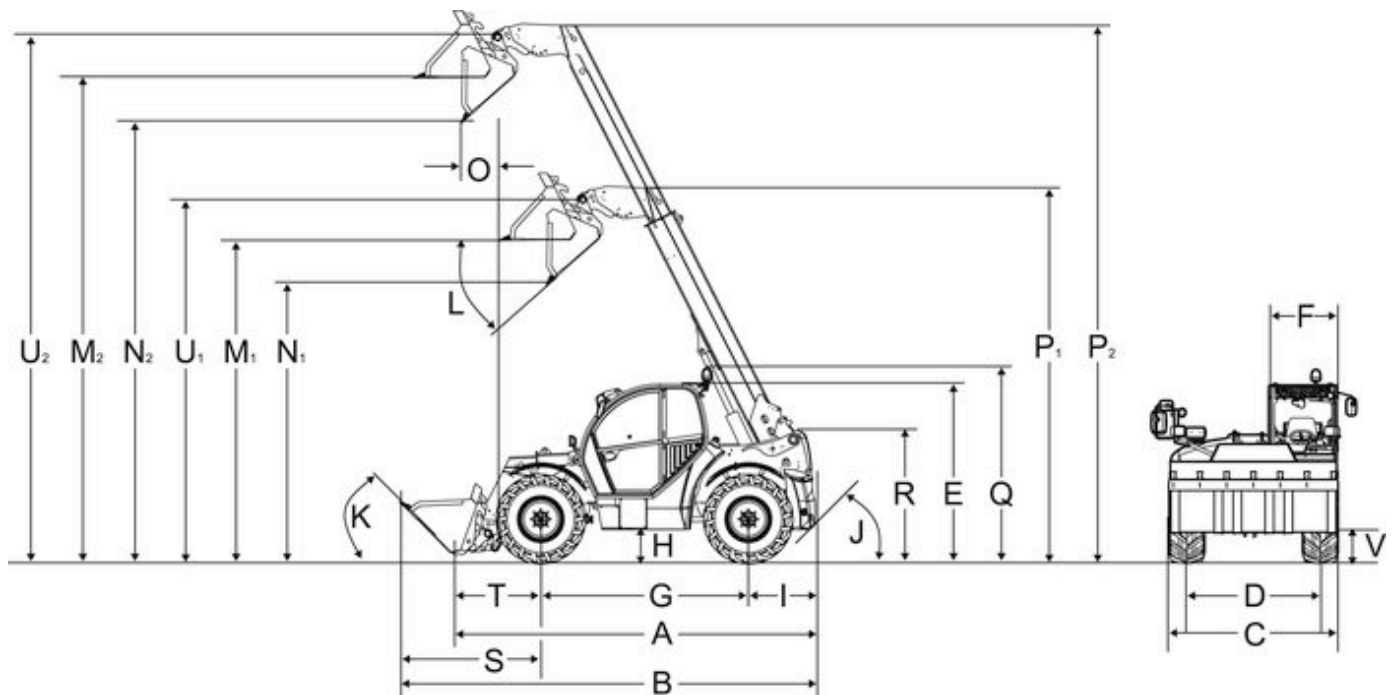

A	Overall length	4,880 mm
B	Overall length with bucket	5,600 mm
C	Overall width without attachment	2,285 mm
D1	Track width front	1,880 mm
D2	Track width rear	1,880 mm
E	Total height	2,310 mm
F	Cabin width	990 mm
G	Wheelbase center	2,850 mm
H	Ground clearance under axle and gearbox	415 mm
I	Distance center of rear wheel to rear	830 mm
J	Rear actuation angle	45 °
K	Tipping angle	49 °
L	Tip-out angle	41 °
M1	Overhead loading height - retracted	4,520 mm
M2	Overhead loading height - extended	6,820 mm
N1	Dumping height - retracted	4,030 mm
N2	Dumping height - extended	6,330 mm
O	Dump reach - extended	110 mm
P1	Length	5,225 mm
P2	Length	7,820 mm
Q	Total height with rotating beacon	2,540 mm
R	Total height of the telescopic arm bearing in the frame	1,600 mm
S	Distance from the front wheel center to the front edge of the bucket	1,920 mm
T	Distance from the center of the bearing of the front wheel to the quick-change frame	1,200 mm
U1	Bucket pivot point - retracted	5,035 mm

U2	Bucket pivot point - extended	7,335 mm
V	Transport position with attachment	250 mm
-	Turning radius at the outer edge of the wheels	3,840 mm
-	Entry height, cabin floor	720 mm
-	Turning radius at the outer edge of the bucket	5,000 mm

Alle Angaben ohne Gewähr.

Maschinenmaße können je nach Bereifung variieren.

„Gesamtlänge“ und „Abstand Mitte Hinterrad zum Heck“:

- mit Hitch-Kupplung + 70 mm (KT276); + 320 mm (KT306,KT356, KT307, KT357, KT447, KT507, KT557); + 154 mm (KT559)

- mit höhenverstellbarer Anhängerkupplung + 320 mm (KT306,KT356, KT307, KT357, KT447, KT507, KT557)

- mit fester Anhängerkupplung + 200 mm (KT306,KT356, KT307, KT357, KT447, KT507, KT557)

„Gesamtbreite ohne Schaufel“ abhängig von der Bereifung, mit eingeklappten Spiegeln

„Hinterer Anfahrwinkel (Böschungswinkel)“ mit Hitch-Anhängerkupplung 51° (KT276); 32° (KT306, KT356, KT307, KT357)

Please note: that product availability can vary from country to country. It is possible that information / products may not be available in your country. More detailed information on engine power can be found in the operator's manual; the stated power may vary due to specific operating conditions. Subject to alterations and errors excepted. Applicable also to illustrations.

Copyright © 2020 Kramer-Werke GmbH.